

Use Hand Tools not Power Tools!!

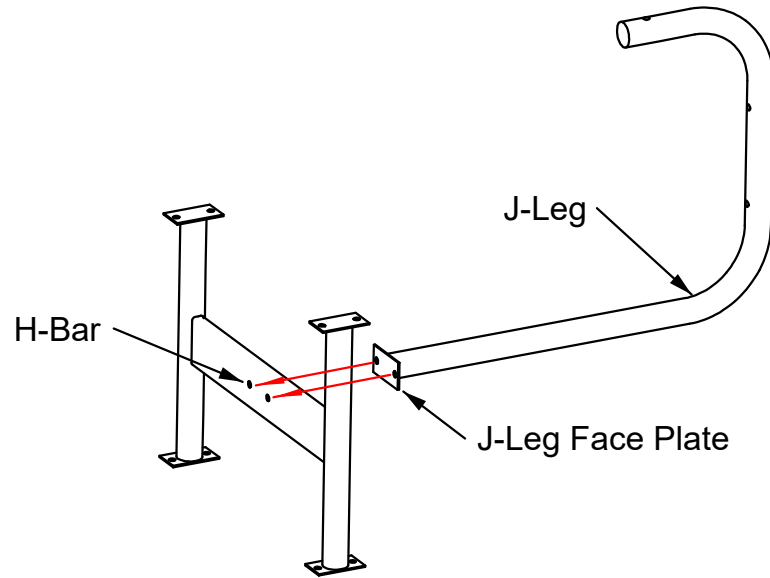

Attach with included 3/8" x 2" Bolts.

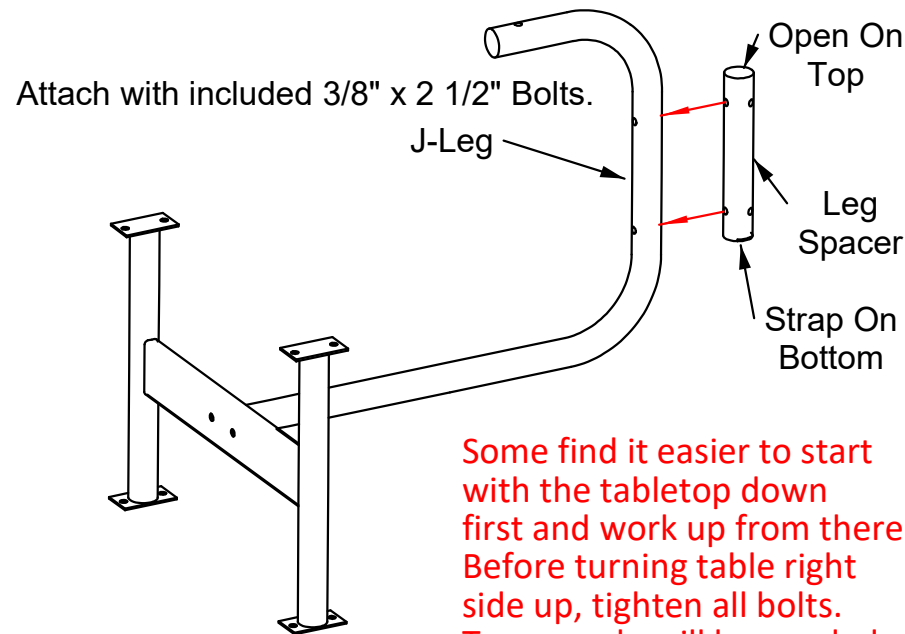
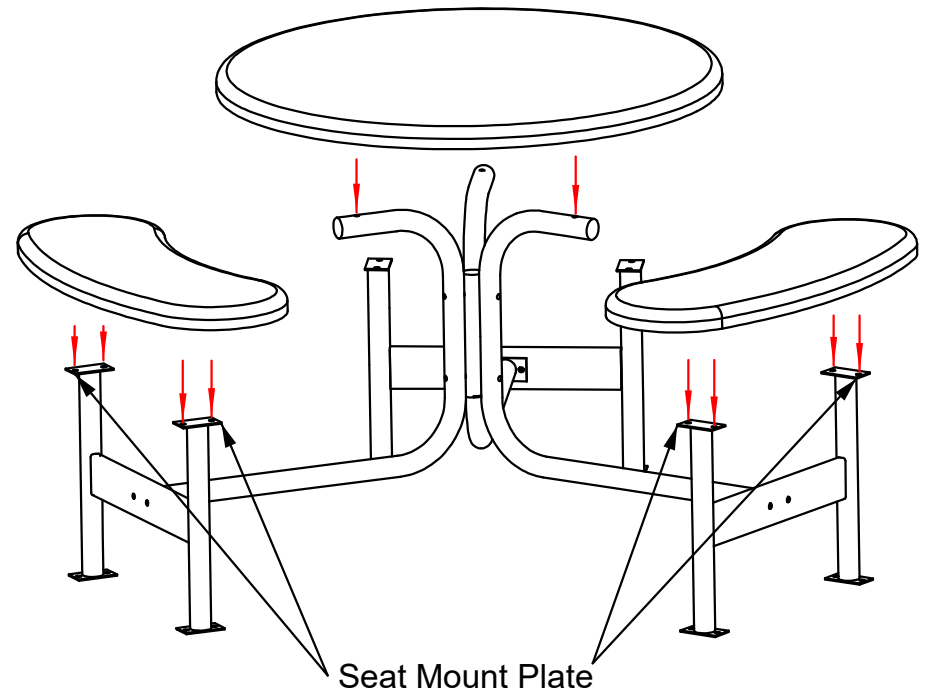

Attach with included 3/8" x 2 1/2" Bolts.

Some find it easier to start with the tabletop down first and work up from there. Before turning table right side up, tighten all bolts. Two people will be needed to turn table over.

Hardware Kit includes:

- 6) 3/8"-16 x 2" 18-8 SS Hex Bolts
- 6) 3/8"-16 x 2-1/2" 18-8 SS Hex Bolts
- 12) 3/8"-16 Nyloc Nuts 18-8 SS
- 24) 3/8" x 7/8" x .05" Flat Washers 18-8 SS

WARNING:

Use of the Table/Umbrella combination without the lower bolt, is UNSAFE!! Wind may dislodge the umbrella, causing Property Damage and/or Personal Injury. Anchoring hardware is NOT included but the table should be anchored to ensure added safety and security.

STM Industries, LLC
9524 N. Trask St,
Tampa, FL, 33624
(813)854-3544

Table Assembly Instructions (Assembly takes about 30 minutes)

Tools needed

- 9/16" socket wrench
- 9/16" open end wrench
- Bottle or tube of Loctite or similar product
- If you have a ratcheting 9/16" box wrench, this will make assembly even faster and make putting the nuts on in the cylinder a lot easier. These are available at most hardware stores.

Bench Supports / J – Leg Assembly

- First, place a blanket or large piece of cardboard on the ground or assemble on a smooth, grassy surface. This will prevent your newly painted seats and tops from being scratched as well as the powder-coated framing.
- Place three H-shaped bench cross bars roughly in a circle, six feet in diameter. Place cross bars at 12, 4 and 8 o'clock (120 degrees apart).
- Find six 2" x 3/8" hex head bolts, twelve washers and six 3/8" hex nuts.
- Insert bolts into washers and place through bench cross bars (with the head away from the center of the circle).
- Place J- Leg face plates over the bolts and secure with a washer and 3/8" hex nut.
- DO NOT TIGHTEN beyond finger tight at this time (this allows for small realignment, later).

J – Leg / Cylinder Leg Spacer Assembly

- Find the large cylindrical leg spacer. Place with inner pole support and pin facing down in center of the three J – Legs
- Find six 2-1/2" bolts, six washers and six plain 3/8" nuts.
- Place washers on bolts and put through J – Legs into Cylinder Leg Spacer.
- Put a drop of Loctite on the inside of each nut and on the end of the bolt just before assembly.
- Place washer and nuts on the inside end of the bolts and FINGER TIGHTEN ONLY. It is easiest to start with the top three bolts and then temporarily support the legs and cylinder to get the bottom three bolts in.
- It is easier to hold the washers and nuts in place and turn the bolt as there is little finger room. This is where the ratcheting box wrench can be handy to hold the nuts.
- Place entire assembly on the flat surface where you want the table (if you haven't already done so).
- Gently partially tighten the nuts but leave some play.

Fiberglass Bench Seat and Tabletop Assembly

- Place Tabletop on tops of J- Legs with the bolts in the tabletop going through the holes on top of the J – Leg. You may need to adjust the legs to realign them with the bolts.
- Place a washer and a regular 3/8" nut on the bolt. Tighten ***gently*** to avoid stripping the head out of the table!
- Remove the nuts and washers from the bench seats.
- Place the bolts on the seats in the top plates of the Bench Cross Bar (H-shape) assemblies.
- FINGER TIGHTEN only.
- Make sure everything is aligned and in place and NOW tighten all of the nuts. ***Remember not to over tighten the nuts that hold the tabletop to the J – leg.***

Umbrella Placement

- Place the umbrella pole into the center hole of the table and position over the center alignment post in the center of the cylindrical leg spacer. Make sure the bottom of the pole is down all of the way to the bottom support in the cylindrical leg spacer.
- With at least two people, carry umbrella upright and insert umbrella support stub into the top end of the pole, aligning the holes in the umbrella stub and the top of the pole.
- Put a washer on the pole bolt, insert into pole and through umbrella stub and out other side. Place washer on the other end of the bolt, followed by the nut. There is no need to tighten too much as the bolt is to keep the umbrella from separating from the pole.
- The second bolt set is to be placed into the lower drilled hole of the pole that is approximately 12" from the bottom of the pole. Place bolt through hole, add the washer and nut and tighten. This bolt will hold the pole into the table and will keep the umbrella from being removed from the table. **Warning: Use of a table/umbrella combination without the lower bolt is UNSAFE. Wind may dislodge the umbrella, causing property damage or personal injury.**

Maintenance

- To clean, use a soft brush and some Dawn. For more stubborn stains or food items, use Comet cleanser (it won't scratch the surface). To give your tables a bit of extra shine, hose them down every now and then and then apply Turtle Wax or carnauba wax.....they will last for years.

Thank you for choosing STM Industries for your tables and umbrellas. They are each custom made, by hand, right here in our shop to ensure that your guests have the best outdoor dining experience. We are proud of our products, and we hope you will be too.

For any additional questions, please call us! We will be glad to help you!

STM Industries, LLC
9524 N. Trask Street
Tampa, FL 33624
813-854-3544